



# INSTA-VALVE PLUS 250 **INSERTION VALVES**

14"–16" Installation Instructions — Revised October 2021



## Table of Contents

<b>SECTION 1 — General Safety Precautions</b>	<b>SECTION 6 — Appendices</b>
1.0.0 General Safety Precautions .....3	Appendix A — Technician Tool List.....17
<b>SECTION 2 — 14”-16” Insta-Valve Plus 250 Installation</b>	Appendix B — Pressure Test Instructions .....18
2.0.0 Mount Valve Body on Pipe .....4	Appendix C — Valve Body Install Instructions .....19
2.1.0 Pressure Test Valve Body .....4	Appendix D — Installation Without Auto Equalization 21
2.2.0 Add Pipe Support / Valve Body Support .....4	Appendix E — Valve Cartridge and Cutter Sizing Information .....25
2.3.0 Install Temporary Gate Valve .....4	Appendix F — Second Valve Cartridge Installation Attempt.....26
<b>Section 3 — Core Sample and Line Tap Procedure</b>	Appendix G — Valve Insertion Without Alignment Gauge Plate .....27
3.0.0 Core Sampling - Setup .....5	Appendix H — Core Sampling Parts Identification .....29
3.1.0 Install Tapping Equipment .....5	
3.2.0 Performing the Core Sample .....6	
3.3.0 Remove the Tapping Equipment .....7	
3.4.0 Post Core Sampling Tapping — Setup .....7	
3.5.0 Install Tapping Equipment .....7	
3.6.0 Post Core Sampling Tapping - Procedure .....8	
3.7.0 Post Core Sampling Tapping - Completion .....8	
<b>Section 4 — Standard, Non-Core Sample Tapping</b>	
4.0.0 Standard Tapping — Setup .....9	
4.1.0 Install Tapping Equipment .....10	
4.2.0 Standard Tapping — Procedure .....10	
4.3.0 Standard Tapping — Completion .....11	
<b>SECTION 5 — Valve Insertion Utilizing Auto Equalization</b>	
5.0.0 Valve Insertion Setup .....12	
5.1.0 Valve Cartridge Insertion .....13	
5.2.0 Complete Installation .....14	

## Section 1.0.0 — General Safety Warnings

These instructions depict the use of the most up-to-date Hydra-Stop insertion valves, installation equipment, and accessories. Please be certain you are following the instructions for your equipment.

### General Safety Precautions — Read and Follow Instructions

Carefully read and understand all safety messages in this manual before using the equipment. The manuals provided with the equalization pump must also be read for safety. The maintenance procedures are to be followed to keep the equipment in good working condition.

### Personal Protection

Hydra-Stop recommends that installers wear required personal protective equipment including but not limited to:

- Hard Hat
- Safety Shoes
- Safety Glasses
- Ear Protection
- Gloves

Avoid wearing jewelry, such as rings, wristwatches, necklaces, or bracelets. If working near traffic, select ear protection that allows you to hear the traffic for safety.

### Keep Spectators Away from Installation Area

Keep all spectators and other workers away from machines and work area(s) while in operation.

### Clear Work Area

Clear the work area of all objects that might interfere with the proper operation of any tools. Avoid placing tools or other objects where they can fall into the pit.

### Do Not Work in an Unsupported Trench

Do not work in trench with unstable sides, which could cave in. Specific requirements for shoring or sloping trench walls are available from several sources including federal and state offices. Be sure to contact suitable authorities for these requirements before working in the trench. A minimum 5'x 5' excavation is recommended.

Locate the existing pipe joints or fittings in the area and use the appropriate restraint methods if necessary.

### Check Laws and Regulations

Know and obey all Federal, State, and local laws and regulations that apply to your work situation.

### Handling the Equipment

To avoid back injury, use proper lifting techniques. Follow all equipment instructions when lifting heavy loads.

### Check Hardware and Equipment

Make sure that all air or hydraulic line couplings are tightened and secured to eliminate the chance of accidental uncoupling. Use hose connection retaining devices such as locking rings, clips, pins, chains, or cables. Identify all equipment and tools necessary for the size of the Insta-Valve Plus 250 you intend to install. Inspect equipment to verify it is in good working condition and free of wear and damage prior to use. Never start an operation if the equipment is not in proper working order. Contact Hydra-Stop if equipment is not in working order.

### Do Not Exceed Load Rating on Any Lifting Equipment

This includes but is not limited to lifting magnets, eyebolts and straps. Lifting magnets provided with Hydra-Stop equipment are labeled with a load rating.

**WARNING:** Failure to follow any of the above safety instructions or those that follow in this manual, could result in serious injury. Any operation involving work on pipe containing liquids or gases under pressure is potentially hazardous. It is necessary, therefore, that correct procedures be followed in the use and maintenance of this equipment to maintain a safe working environment.

No person should use this equipment who is not fully trained in the procedures stated in this manual, and who is not fully aware of the potential hazards connected with work on pipe containing liquids or gases under pressure.

The purchaser of this equipment is responsible for the way this equipment is used, maintained, and the training, competence and safety of the operators.

Should any difficulty arise at any time in the use of this equipment, please contact Hydra-Stop at 708-389-5111 immediately.

## 2.0.0 Mount Valve Body on Pipe

**2.0.1)** Refer to Appendix A — 14"–16" Insta-Valve Plus 250 Valve Body Installation Instructions for complete instructions (page 19).

### 2.1.0 Pressure Test Valve Body

**NOTE:** A pressure test must be performed to verify that the Insta-Valve Plus 250 valve body is properly sealed onto the pipe before tapping. See Appendix B — Using a Standard Pressure Test Flange to Pressure Test for details (page 18).

**2.1.1)** Apply food-grade grease from the chamfer on the inside edge of the top flange to the step down approximately 6 inches down from the top edge. This grease will supply lubrication for the valve cartridge insertion process.

**2.1.2)** Fill the valve body with water (approximately 30 gallons will be needed).

**2.1.3)** Place the O-ring in the O-ring groove on the top of the flange.

**2.1.4)** Place the test flange on top of the O-ring.

**2.1.5)** Bolt the test flange, provided with the installation equipment, in place. To prevent galling, use galvanized steel nuts and bolts to secure the test flange, not the stainless-steel nuts and bolts that are provided with the Insta-Valve Plus 250.

**2.1.6)** Connect the test flange to a hand or mechanical pump and pressurize the valve body.

**NOTE:** Do not exceed recommended pressure test specifications. Minimum Test Pressure: 1.5 times the system working pressure. Maximum Test Pressure: 375 psi. Hydra-Stop recommends using a hydro-static method of pressurizing the valve body. **DO NOT** use a compressible medium such as air. **NOTE:** Caution should be taken when pressure testing above the line pressure on thin walled, flexible, or brittle conditions to avoid damaging the pipe wall.

**2.1.7)** Isolate the pressure to the valve body and hold the pressure for the length of time required by the pressure test. Tighten any plugs on the outside diameter of the valve body flange if there is any leakage.

**NOTE:** The valve installer and the end user are to determine the pressure and length of time for the test.

**2.1.8)** Upon successful completion of the pressure test, relieve the pressure in the valve body and remove the test flange.

**2.1.9)** After 15 minutes have passed since the valve body was pressurized, re-torque all the bolts again to the specified torque found in Appendix A.

## Section 2.2.0 Add Pipe / Valve Body Support

2.2.1 Support precautions:

- Pour concrete around the clamp portion of the valve body. 4,000 lb. high-early strength concrete is recommended.

- Minimum height of concrete is to be just above the top lug bar of the valve body clamp.
- It is the responsibility of the installer to work with the end user of the valve to determine what pipe support is necessary for the given application, considering soil conditions.

## Section 2.3.0 Install Temporary Gate Valve

**2.3.1)** Place a green fiber gasket from the Insta-Valve Plus 250 installation kit on the top flange of the valve body.



Figure 1

**2.3.2)** Install and center the temporary gate valve on the top flange of the valve body (see Figure 1).

**NOTE:** A rubber gasket should not be used.

**CRITICAL NOTE:** To install the 14"–16" Insta-Valve Plus 250, the 16" temporary gate valve must be bored to 16.500". Check this measurement before beginning installation.

Immediately call Hydra-Stop Technical Support at 708-389-5111 if your temporary gate valve bore is smaller than 16.500". **DO NOT PROCEED WITH INSTALLATION.**

**2.3.3)** Place the threaded studs of the temporary gate valve through the bolt holes on the top flange of the Insta-Valve Plus 250. Align the temporary gate valve with the pipe.

**Note:** The use of alignment nuts positions the temporary gate valve and the insertion housing in proper alignment with the valve body to successfully install the valve cartridge.

**2.3.4)** Thread 2 alignment nuts onto the studs which connect the temporary gate valve to the Insta-Valve Plus 250 valve body flange. Place these nuts at the locations shown in Figure 2A.

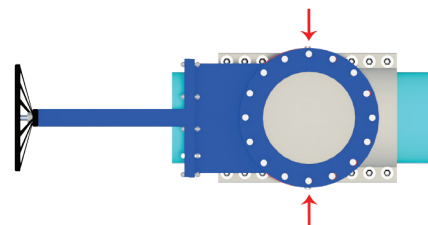

Figure 2A - Alignment nut placement for temporary gate valve alignment

Figure 2A

Install alignment nuts so that the tapered part of the nut enters

the flange hole. This may require adjustment of the gate valve. Figure 2B shows the installed temporary gate valve alignment

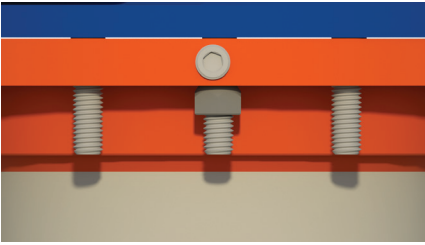

Figure 2B — Installed Temporary Gate Valve Alignment Nuts

nut.

**2.3.5)** Tighten the alignment nuts.

**2.3.6)** Thread the remaining nuts over the temporary gate valve studs. Tighten all nuts evenly and gradually in a crossing pattern.

**NOTE:** For studs below the temporary gate, do not tighten nuts onto studs that are bottomed out inside the gate valve (leave a small gap). This can cause the valve body to squeeze the gate and make the gate valve hard to operate.

**2.3.7)** Place the second green fiber gasket onto the top raised face of the temporary gate valve, centered with the port.

**NOTE:** Follow Section 3 if you are performing a core sample prior to valve insertion. Proceed to Section 4 if you are performing a standard, non-core sample line tap in preparation of valve insertion.

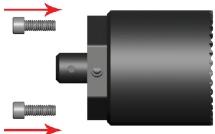

Figure 3

**Section 3 Core Sample Setup**

**3.0.1)** Screw the 4-inch core sampling cutter to the adaptor and lock in place with cutter hardware (see Figure 3).

**3.0.2)** Insert pilot bit into adaptor and lock in place with set pin (see Figure 4).

**3.0.3)** Thread adaptor/cutter onto the 75" saw mandrel until tight (nylon locking feature will prevent adaptor from unthreading), hex pattern may be used for tightening/ loosening (see Figure 5).

**3.0.4)** Attach centering ring to centering ring adaptor plate using (4) 1/2"-13 x 2.5" hardware. It is recommended that the locking nuts be placed on the adaptor plate side (see Figure 6).

**3.0.5)** Attach centering ring adaptor plate to top of 14"–16" saw mandrel plate using (3) 1/2"-13 x 2.0" rounded socket head cap screws and locking nuts. It is recommended that screws be threaded from the bottom of the

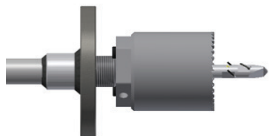

Figure 4

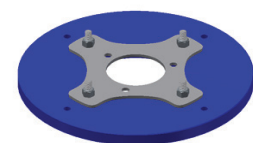

Figure 5

Figure 6

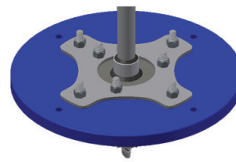

Figure 7

mandrel plate as shown (see Figure 7).

**3.0.6)** Apply grease to the packing nut O-ring (see Figure 8) and the end of the cutter assembly's saw mandrel shaft on and around the taper (see Figure 9).



Figure 8

**3.0.7)** With the installation housing lying on its side, insert the cutter assembly, shaft first, into the housing and through the packing nut until the cutter and its pilot drill are completely inside the housing (see Figure 10).



Figure 9

**3.0.8)** Tighten the clamp lever in the packing nut to secure the cutter assembly in the housing.

**Section 3.1 Install Tapping Equipment**

**3.1.1)** Using lift support and a strap around the P3, place the installation housing onto the temporary gate valve so the threaded studs of the temporary gate valve fit through the bolt holes at the bottom of the housing (See Figure 11). The port on the side of the housing is to be aligned with the pipe.

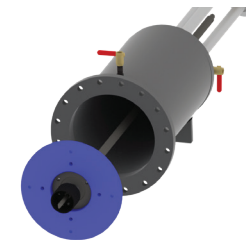

Figure 10

**3.1.2)** Thread 2 alignment nuts onto the studs which connect the insertion housing to the temporary gate valve. Place these nuts at the locations shown (see Figure 12 on following page). Install alignment nuts so that the tapered part of the nut enters the flange hole. This may require adjustment of the tapping / installation housing.

Figure 13 on the following page shows the installed tapping / installation housing alignment nut.

**3.1.3)** Thread nuts over the remaining temporary gate valve studs.

**3.1.4)** Tighten all nuts evenly and gradually in a cross-tightening pattern.



Figure 11

**3.1.5)** Loosen the Allen-cap screw in the packing nut and slowly lower the core sampling cutter through the Insta-Valve Plus until the pilot drill contacts the pipe. Spin cutter to ensure it is moving freely.

**3.1.6)** Slide a stop collar onto the saw mandrel.

**3.1.7)** Set the cutting depth by measuring from the top of the packing nut assembly to the lower side of the stop collar.

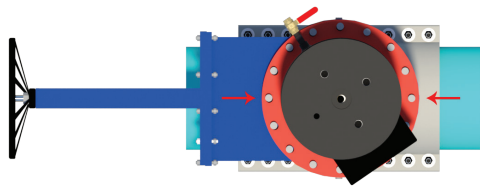

Figure 12 — Alignment nut placement for insertion housing alignment

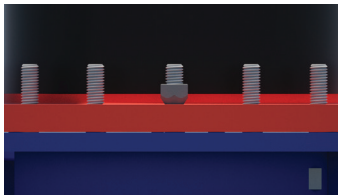

Figure 13

- 14" pipe = 5" cutting depth
- 16" pipe = 5" cutting depth

**3.1.8)** Tighten the stop collar to the correct measurement (see Figure 14).

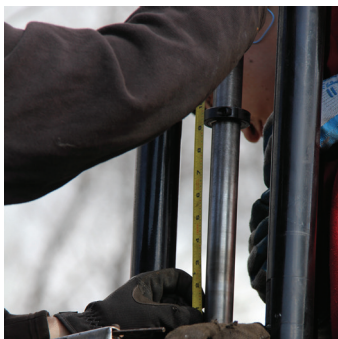

Figure 14

**3.1.9)** Install the drive unit by lifting it above the saw mandrel and slide it into the three guide bars.

**3.1.10)** Lower the drive unit onto the machined hex of the saw mandrel. Confirm the drive unit is fully seated onto the machined hex of the saw mandrel (see Figure 15).

**3.1.11)** Thread the feed screw into the P3 until it bottoms out on the drive motor and back off the feed screw 1/2 turn, leaving a small gap (see Figure 16).

**3.1.12)** Install the upper and lower restraint pins and cotter clips to join the saw mandrel, drive motor and feed screw into a single assembly. Early models of Hydra-Stop 14"–16" Insta-Valve installation equipment did not include the drive motor restraint kit. If you do not have the drive motor restraint kit, proceed to Step 3.2.1.

**Section 3.2 Performing the Core Sample**

**3.2.1)** Open the ball valves on the side and top of the installation housing to allow air to be purged from the installation housing while the housing is filling.

**3.2.2)** Connect the drive unit power source to the drive unit. The air drive unit requires 90 CFM at 90 Psi. The hydraulic drive unit requires 9 GPM at



Figure 15

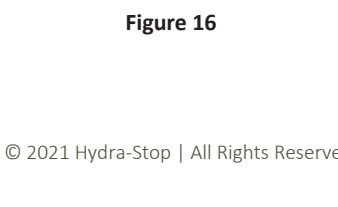

Figure 16

1800 Psi.

**3.2.3)** Engage the drive motor so the saw mandrel is turning clockwise. Turn the feed screw in a clockwise direction using light and consistent force. Air and fluid will start coming out of the ball valves as the housing fills from the pilot drill penetrating the pipe wall.

**3.2.4)** Close the valve on the side of the installation housing after the pilot drill has pierced the pipe and water has reached that level. Close the top valve when installation housing has filled with water.

**3.2.5)** Continue to advance the cutter into the pipe until the stop collar reaches the packing nut assembly. The tap is complete when the bottom of the stop collar contacts the top of the packing nut assembly.

**NOTE:** Depending on wall thickness of the tapped pipe, the tap may be complete before the bottom stop collar is reached. In this case, continue to advance the cutter until the stop collar is reached. Additional cutter travel will not adversely affect the core tap.

**3.2.6)** When the tap is complete, shut off the drive motor.

**3.2.7)** If using the drive motor restraint system, turn the handles of the OS&Y feed screw counterclockwise to retract the cutter assembly. Otherwise, follow Steps 3.2.8–3.2.12 below.

**3.2.8)** Tighten the packing nut by turning the Allen-cap screw in the clockwise direction.

**3.2.9)** Unthread the feed screw out of the P3.

**3.2.10)** Remove the drive motor.

**WARNING:** Exercise caution when placing your hands inside the triangle formed by the three guide bars. NEVER place your hands between the saw mandrel and the P3 of the insertion housing.

**3.2.11)** Place the closed end of a combination wrench over the shaft of the saw mandrel and slowly loosen the clamp lever in the packing nut to allow the saw mandrel to slowly rise under pressure (see Figure 17).



Figure 17

Apply downward force to the wrench to control the speed of the upward movement. When the saw mandrel is within 6" of the P3, tighten the clamp lever to hold the saw mandrel so you can remove the wrench before the

saw mandrel passes through the P3, then loosen the packing nut slowly to finish the upward travel of the saw mandrel.

**3.2.12)** Pull up on the saw mandrel if pressure alone is not enough to raise the cutter until it is completely inside of the housing and clear of the temporary gate valve.

**NOTE:** If pipe pressure is very low and there is difficulty raising the cutter opening the top valve on installation housing allows the cutter to rise.

**3.2.13)** Confirm the cutter assembly is completely retracted into the housing.

**NOTE:** Damage to cutter assembly or gate valve will occur if cutter assembly is NOT completely retracted when the temporary gate valve is closed.

**3.2.14)** Tighten the packing nut when the cutter and pilot drill are completely inside of the installation housing. The hexagon end of the saw mandrel should be at or near the OS&Y Assembly (see Figure 18).

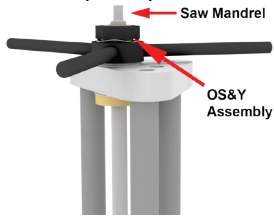

Figure 18

**3.2.15)** Fully close the temporary gate valve.

**3.2.16)** Open the top and side ports in the installation housing to drain the water inside of the housing.

### Section 3.3 Remove the Tapping Equipment



Figure 19

**3.3.1)** Remove the nuts securing the installation housing to the temporary gate valve.

**3.3.2)** Secure a strap around the P3 of the installation housing and lift the installation housing off the temporary gate valve and lay it on its side above ground, preferably on a hard, flat surface (see Figure 19).

**3.3.3)** Loosen the packing nut and the stop collar on the saw mandrel shaft.

**3.3.4)** Pull the cutter assembly out of the installation housing. Loosen the packing nut for ease of removal.

**3.3.5)** Remove the coupon by unthreading the pilot drill from the saw mandrel stud.

**3.3.6)** Flip the pilot drill and insert it point end through the hole in the coupon past the retaining clips and use it to pull the coupon out of the cutter.

**CAUTION:** Wear gloves when removing the coupon. Coupon edges may be sharp.

**3.3.7)** Inspect to ensure the O-ring at the inside diameter of the packing nut is in good condition. Replace the O-ring if necessary.

**NOTE:**

- Centering ring ensures this 4" sample tap is centered.
- Check that centering ring can rotate freely with pilot bit touching the pipe.
- The 4" tap can generate extra heat. It is recommended that this 4" sample tap is done at a slower than average speed if done on PVC.

### Section 3.4 Post Core Sample Tapping — Setup



Figure 20

**3.4.1)** Thread centering tool extension completely onto 75" saw mandrel. Flats may be used with crescent or 1-1/16" wrench (see Figure 20).

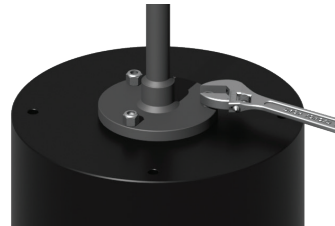

Figure 21

**3.4.2)** Thread cutter onto saw mandrel completely, then back off until the 3 equally spaced holes in the cutter align with the threaded holes of the saw mandrel. Secure cutter with three 1/2"-13 screws and lock nuts (see Figure 21).

**3.4.3)** Insert 4-inch centering tool into extension adapter, align through-hole with extension through-hole and lock in place with cotter pin & clip (see Figure 22).

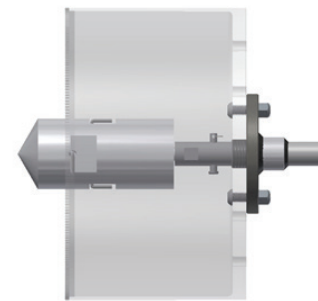

Figure 22

**3.4.4)** Apply grease to the packing nut O-ring (see Figure 23) and the end of the cutter assembly's saw mandrel shaft on and around the taper (see Figure 24).



Figure 23

**3.4.5)** With the installation housing lying on its side, insert the cutter assembly, shaft first, into the housing and through the packing nut until the cutter and its pilot drill are completely inside the housing (see Figure 25).



Figure 24

**3.4.6)** Tighten the packing nut by turning the Allen-cap screw in the clockwise direction to secure the cutter assembly in the housing.

### Section 3.5 Install Tapping Equipment

**3.5.1)** Using lift support and a strap around the P3, place the installation housing onto the temporary gate valve so the threaded studs of the temporary gate valve fit through the bolt holes at the bottom of the housing (see Figure 26 on next page). The port on the side of the housing is to be aligned with the pipe.



Figure 25

**3.5.2)** Thread 2 alignment nuts onto the studs which connect the insertion housing to the temporary gate valve. Place these



Figure 26

nuts at the locations shown in Figure 27.

Install alignment nuts so that the tapered part of the nut enters the flange hole. This may require adjustment of the tapping / installation housing.

Figure 28 shows the installed tapping / installation housing alignment nut.

**3.5.3)** Thread nuts over the remaining temporary gate valve studs.

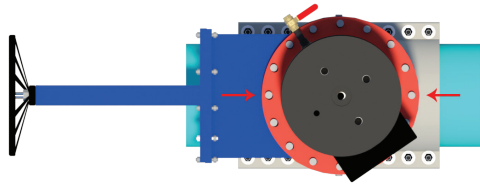

Figure 27 — Alignment nut placement for insertion housing alignment

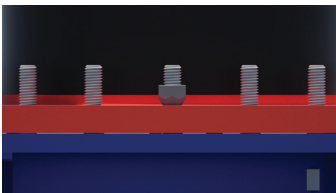

Figure 28

**3.5.4)** Tighten all nuts evenly and gradually in a cross-tightening pattern.

**Section 3.6 Post Core Sample Tapping Procedure**

**3.6.1)** Loosen the Allen-cap screw in the packing nut and slowly lower the cutter through the Insta-Valve Plus until the cutter contacts the pipe. Spin cutter in a clockwise direction to ensure it is moving freely.

**3.6.2)** Slide a stop collar onto the saw mandrel and use this stop collar as your mechanical stop for tapping depth. The stop collar should be set at a distance equal to half the outside diameter of the pipe that is to be tapped (for example, use 8.70" for a pipe that measures 17.4" in OD or 7.65" for a pipe that measures 15.3" OD (see Figure 29).

**3.6.3) CRITICAL STEP:** Setting the stop collar in the proper position prevents cutting into the inside diameter of the pipe, which causes leakage, and ensures a complete tap has been made.

**3.6.4)** Install the drive unit by



Figure 29

lifting it above the saw mandrel and slide it into the three guide bars (see Figure 30)

**3.6.5)** Lower the drive unit onto the machined hex of the saw mandrel. Confirm the drive unit is fully seated onto the machined hex of the saw mandrel.

**3.6.6)** Thread the feed screw into the P3 until it bottoms out on the drive motor and back off the feed screw 1/2 turn, leaving a small gap (see Figure 31).



Figure 31

**3.6.7)** Install the upper and lower restraint pins and cotter clips to join the saw mandrel, drive motor, and feed screw into a single assembly.

**3.6.8)** Open the ball valves on the side and top of the installation housing to allow air

to be purged from the installation housing while the housing is filling.

**3.6.9)** Connect the drive unit power source to the drive unit. The air drive unit requires 90 CFM at 90 Psi. The hydraulic drive unit requires 9 GPM at 1800 Psi.

**3.6.10)** Engage the drive motor so the saw mandrel is turning clockwise. Turn the feed screw in a clockwise direction using light and consistent force. Air and fluid will start coming out of the ball valves as the housing fills from the pilot drill penetrating the pipe wall.

**3.6.11)** Close the valve on the side of the installation housing after the pilot drill has pierced the pipe and water has reached that level. Close the top valve when installation housing has filled with water.

**3.6.12)** Continue to advance the cutter into the pipe until the stop collar reaches the packing nut assembly. The tap is complete when the bottom of the stop collar contacts the top of the packing nut assembly.

**3.6.13)** When the tap is complete, shut off the drive motor.

**3.6.14)** Tighten the packing nut by turning the Allen-cap screw in the clockwise direction.

**3.6.15)** Unthread the feed screw out of the P3.

**3.6.16)** Remove the drive motor.

**3.6.17)** If you used the drive motor restraint system, use the handles of the OS&Y feedscrew to retract the cutter assembly. Otherwise, follow steps 3.7.1–3.7.3.

**Section 3.7 Post Core Sample Tapping Completion**

**WARNING:** Exercise caution when placing your hands inside the triangle formed by the three guide bars. NEVER place your hands between the saw mandrel and the P3 of the insertion housing.

**3.7.1)** Place the closed end of a combination wrench over the shaft of the saw mandrel and slowly loosen the clamp lever in the packing nut to allow the saw mandrel to slowly rise under





Figure 32

pressure (see Figure 32).

Apply downward force to the wrench to control the speed of the upward movement. When the saw mandrel is within 6" of the P3, tighten the clamp lever to hold the saw mandrel so you can remove the wrench before the saw mandrel passes through the P3, then loosen the packing nut slowly to

finish the upward travel of the saw mandrel.

**3.7.2)** Pull up on the saw mandrel, if pressure alone is not enough to raise the cutter, until it is completely inside of the housing and clear of the temporary gate valve.

**NOTE:** If pipe pressure is very low, and there is difficulty raising the cutter, opening the top valve on installation housing allows the cutter to rise.

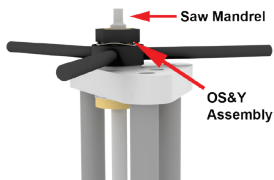

Figure 33

**3.7.3)** Tighten the clamp lever in the packing nut when the cutter and pilot drill are completely inside of the installation housing. The hexagon end of the saw mandrel should be at or near the OS&Y Assembly (see Figure 33).

**3.7.4)** Fully close the temporary gate

valve.

**3.7.5)** Open the top and side ports in the installation housing to drain the water inside of the housing.

**3.7.6)** Remove the nuts securing the installation housing to the temporary gate valve.



Figure 34

**3.7.7)** Secure a strap around the P3 of the installation housing, lift the installation housing off the temporary gate valve, and lay it on its side above ground, preferably on a hard, flat surface (see Figure 34).

**3.7.8)** Loosen the clamp lever in the packing nut and the two stop collars on the saw mandrel shaft.

**3.7.9)** Pull the cutter assembly out of the installation housing. The packing nut can be loosened for ease of removal.

**3.7.10)** Remove the coupon by removing the centering tool from the extension adapter.

**3.7.11)** Flip the centering tool and insert it point-end through the hole in the coupon past the retaining clips and use it to pull the coupon out of the cutter.

**CAUTION:** Wear gloves when removing the coupon. Coupon edges may be sharp.

**3.7.12)** Inspect to ensure the O-ring at the inside diameter of the

packing nut is in good condition. Replace the O-ring if necessary.

After completion of the above step, proceed to Section 5.0 Valve Insertion Setup.

### Section 4.0 Standard Tapping — Setup

**NOTE:** Verify correct cutter / valve cartridge is used or your installation. Refer to Appendix E — Valve Cartridge and Cutter Sizing Information on page 25 of this document.

Contact Hydra-Stop to confirm the correct size valve is being used for your application. If the cutter assembly is already complete, check to make sure all hardware is tight before tapping.

**4.0.1)** Thread the cutter onto the saw mandrel until it bottoms out.

**4.0.2)** Turn the saw mandrel counterclockwise until the bolt holes in the saw mandrel plate are aligned with the bolt holes in the cutter.

**4.0.3)** Thread a 2-inch-long cap screw into the saw mandrel plate through the inside of the cutter until it bottoms out on the inside face of the cutter.

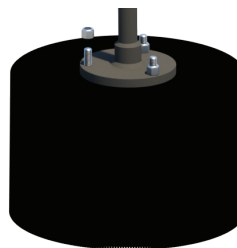

Figure 35

**4.0.4)** Thread a locknut onto the screw until it bottoms out and is tight. Repeat for the other two 2-inch-long cap screws (see Figure 35).

**4.0.5)** Place the cutter centering ring over the saw mandrel and slide until it rests on the saw mandrel plate. Align the centering ring holes with the bolt holes in the cutter.

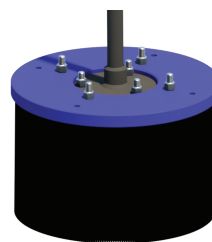

Figure 36

Hydra-Stop recommends the use of centering rings on all 14" and 16" cutter sizes.

**4.0.6)** Place a screw through the bottom of the cutter and through the bolt hole in the inside pattern of holes closest to the center of the centering ring.

**4.0.7)** Thread a locknut onto the screw to tightly secure the centering ring to the cutter. Repeat for the other three screws (see Figure 36).

**4.0.8)** Thread the pilot drill into the end of the saw mandrel shaft inside of the cutter until it bottoms out, ensuring the threads are tight.

**4.0.9)** Measure and record the distance the pilot drill extends past the cutter teeth. This measurement will be used to determine the cutter travel for tapping.

**NOTE:** The distance the pilot drill extends past the cutter teeth can be easily measured using a tape measure by placing a flat piece of wood, such as a yard stick, or similar across the cutter

teeth and against the pilot drill. Measure the distance from the flat surface in contact with the cutter teeth to the end of the pilot drill.



Figure 37

**4.0.10)** Install the Insta-Valve Plus guide plate, which is compatible with the 2" OD guide bars, to the bottom of the drive motor if necessary. The thicker Insta-Valve Plus guide plate is to be installed with the longer cap screws, which are included in the Insta-Valve Plus kit.



Figure 38

**4.0.11)** Apply grease to the packing nut O-ring (see Figure 37) and the end of the cutter assembly's saw mandrel shaft on and around the taper (see Figure 38).



Figure 39

**4.0.12)** With the installation housing lying on its side, insert the cutter assembly, shaft first, into the housing and through the packing nut until the cutter and its pilot drill are completely inside the housing (see Figure 39).



Figure 40

**4.0.13)** Record the distance the saw mandrel shaft extends past the P3. This measurement will be used after tapping to ensure the cutter is fully retracted into the housing (see Figure 40).

**4.0.14)** Tighten the clamp lever in the packing nut by turning the Allen-cap screw in the clockwise direction to secure the cutter assembly in the housing.

### Section 4.1 Install Tapping Equipment



Figure 41

**4.1.1)** Using lift support and a strap around the P3, place the installation housing onto the temporary gate valve so the threaded studs of the temporary gate valve fit through the bolt holes at the bottom of the housing (see Figure 41). The port on the side of the housing is to be aligned with the pipe.

**4.1.2)** Thread 2 alignment nuts onto the studs which connect the insertion housing to the temporary gate valve. Place these nuts at the locations shown in Figure 42.

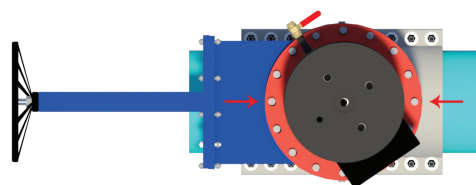

Figure 42 — Alignment nut placement for insertion housing alignment

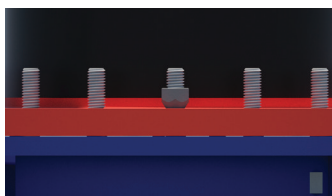

Figure 43

Install alignment nuts so that the tapered part of the nut enters the flange hole. This may require adjustment of the tapping / installation housing alignment nut.

**4.1.3)** Thread nuts over the remaining temporary gate valve studs.

**4.1.4)** Tighten all nuts evenly and gradually in a cross-tightening pattern.

### Section 4.2 Standard Tapping — Procedure

**4.2.1)** Loosen the Allen-cap screw in the packing nut and slowly lower the cutter through the Insta-Valve Plus until the pilot drill contacts the pipe. Spin cutter to ensure it is moving freely.

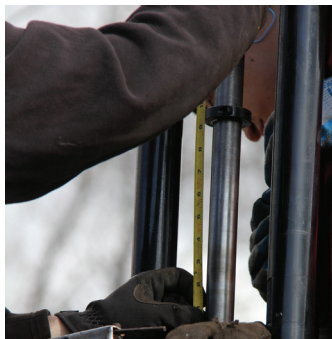

Figure 44

**4.2.2)** Slide a stop collar onto the saw mandrel and use this stop collar as your mechanical stop for tapping depth. The stop collar should be set at a distance equal to half the outside diameter of the pipe that is to be tapped (for example, use 8.70" for a pipe that measures 17.4" in OD or 7.65" for a pipe that measures 15.3" OD (see Figure 44).

**4.2.3) CRITICAL STEP:** Setting the stop collar in the proper position prevents cutting into the inside diameter on the bottom half of the pipe, which causes leakage, and ensures a complete tap has been made.



Figure 45

**4.2.4)** Install the drive unit by lifting it above the saw mandrel and slide it into the three guide bars.

**4.2.5)** Lower the drive unit onto the machined hex of the saw mandrel. Confirm the drive unit is fully seated onto the machined hex of the saw mandrel (see Figure 45).

**4.2.6)** Thread the feed screw into the P3 until it bottoms out



Figure 46

on the drive motor and back off the feed screw 1/2 turn, leaving a small gap (see Figure 46).

**4.2.7)** Install the upper and lower restraint pins and cotter clips to join the saw mandrel, drive motor and feed screw into a single assembly. If you do not have the drive motor restraint kit, proceed to step 4.2.8.

**4.2.8)** Open the ball valves on the side and top of the installation housing to allow air to be purged from the installation housing while the housing is filling.

**4.2.9)** Connect the drive unit power source to the drive unit. The air drive unit requires 90 CFM at 90 Psi. The hydraulic drive unit requires 9 GPM at 1800 Psi.

**4.2.10)** Engage the drive motor so the saw mandrel is turning clockwise. Turn the feed screw in a clockwise direction using light and consistent force. Air and fluid will start coming out of the ball valves as the housing fills from the pilot drill penetrating the pipe wall.

**4.2.11)** Close the valve on the side of the installation housing after the pilot drill has pierced the pipe and water has reached that level. Close the top valve when installation housing has filled with water.

**4.2.12)** Continue to advance the cutter into the pipe until the stop collar reaches the packing nut assembly. The tap is complete when the bottom of the stop collar contacts the top of the packing nut assembly.

**NOTE:** Depending on wall thickness of the tapped pipe, the tap may be complete before the bottom stop collar is reached. In this case, continue to advance the cutter until the stop collar is reached. Additional cutter travel will not adversely affect the tap.

**4.2.13)** When the tap is complete, shut off the drive motor.

**4.2.14)** Tighten the clamp lever in the packing nut by turning the Allen-cap screw in the clockwise direction.

**4.2.15)** Unthread the feed screw out of the P3.

**4.2.16)** Remove the drive motor.

**4.2.17)** If you used the drive motor restraint system, use the handles of the OS&Y feedscrew to retract the cutter assembly. Otherwise, follow steps 4.3.1–4.3.3 below.

### Section 4.3 Standard Tapping — Completion

**WARNING:** Exercise caution when placing your hands inside the triangle formed by the three guide bars. NEVER place your hands between the saw mandrel and the P3 of the insertion housing.

**4.3.1)** Place the closed end of a combination wrench over the shaft of the saw mandrel and slowly loosen the clamp lever in the packing nut to allow the saw mandrel to slowly rise under pressure (see Figure 47).



Figure 47

Apply downward force to the wrench to control the speed of the upward movement. When the saw mandrel is within 6" of the P3, tighten the clamp lever to hold the saw mandrel so you can remove the wrench before the saw mandrel passes through the P3, then loosen the packing nut slowly to finish the upward travel of the saw mandrel.

**4.3.2)** Pull up on the saw mandrel if pressure alone is not enough to raise the cutter until it is completely inside of the housing and clear of the temporary gate valve.

**NOTE:** If pipe pressure is very low, and there is difficulty raising the cutter, opening the top valve on installation housing allows the cutter to rise.

**4.3.3)** Tighten the clamp lever in the packing nut when the cutter and pilot drill are completely inside of the installation housing. Fully close the temporary gate valve.

**4.3.4)** Open the top and side ports in the installation housing to drain the water inside of the housing.

**4.3.5)** Remove the nuts securing the installation housing to the temporary gate valve.



Figure 48

**4.3.6)** Secure a strap around the P3 of the installation housing and lift the installation housing off the temporary gate valve and lay it on its side above ground, preferably on a hard, flat surface (see Figure 48).

**4.3.7)** Loosen the clamp lever in the packing nut and the two stop collars on the saw mandrel shaft.

**4.3.8)** Pull the cutter assembly out of the installation housing. The packing nut can be loosened for ease of removal.

**4.3.9)** Remove the coupon by removing the pilot drill from the saw mandrel.

**4.3.10)** Flip the pilot drill and insert it point-end through the hole in the coupon past the retaining clips and use it to pull the coupon out of the cutter.

**CAUTION:** Wear gloves when removing the coupon. Coupon edges may be sharp.

**4.3.11)** Inspect to ensure the O-ring at the inside diameter of the packing nut is in good condition. Replace the O-ring if necessary.

After completion of the above step, proceed to Section 5.0 Valve Insertion Setup.

**Section 5.0 Valve Insertion Setup Utilizing Auto Equalization**

**NOTE:** If you elect to not utilize the auto equalization features, please see Appendix B — Valve Insertion Without Utilizing Auto Equalization to complete your valve insertion installation.

**5.0.1)** Measure and record the distance from the center of one of the eight ports on the outside diameter of the Insta-Valve Plus valve body flange to the top of the gasket lying flat on the top face of the temporary gate valve. This dimension will be used later to set the travel of the valve cartridge.

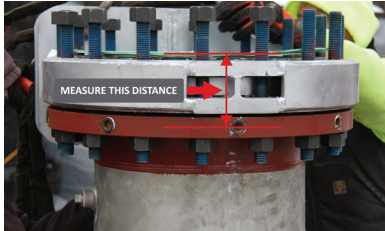

Figure 49

If you are using a standard Hydra-Stop temporary gate valve, the measurement will be approximately 4 5/8 inches (see Figure 49).

**5.0.2)** Check to make sure the valve stem of the valve cartridge is tight and in the open position. Turn the operating nut in the open direction until tight, if necessary.

**5.0.3)** Unthread the retention nut and remove the operating nut from the valve stem.

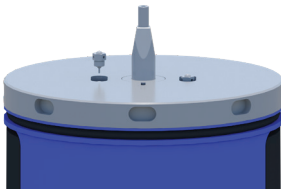

Figure 50

**NOTE:** Unthread the 3/8" NPT plugs from the two auto equalization check valves using an Allen-wrench.

**5.0.4)** Hand tighten the auto-e pins into the check valves. Push down the pin to ensure it can actuate (see Figure 50).

**5.0.5)** Place the head of the insertion tool over the valve stem protruding from the top of the valve cartridge, and align the square pegs on the insertion tool head with the slots in the completion plug on the top of the valve cartridge.

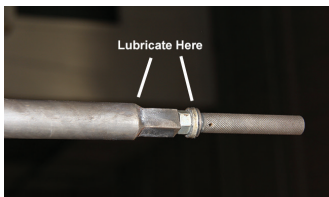

Figure 51

**5.0.6)** Add grease to the top of the insertion tool jam nut below the knurled handle (see Figure 51).

**5.0.7)** Thread the insertion tool onto the valve stem threads on the top of the valve assembly by turning the knurled handle on the top of the insertion tool in the clockwise direction until fully threaded. The head of the insertion tool bottoms out on the completion plug when it is fully threaded.

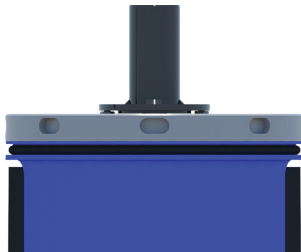

Figure 52

**NOTE:** Ensure that the auto-e pins have been actuated by the insertion tool (see Figure 52).

**5.0.8)** Use an open-end wrench to tighten the 3/4" jam nut.

**CRITICAL STEP:** This step prevents rotation of the valve cartridge during insertion.

**5.0.9)** Add grease to the end of the insertion tool where the round shaft transitions to a chamfer (see Figure 51).



Figure 53

**5.0.10)** Add grease to the packing nut O-ring (see Figure 53).

**5.0.11)** Assemble the cartridge alignment plate by threading in two of the 3/8" threaded alignment pins. When installing a 14" cartridge, the holes closer to the center of the plate should be used. When installing a 16" cartridge, the holes further from center should be used (see Figure 54).

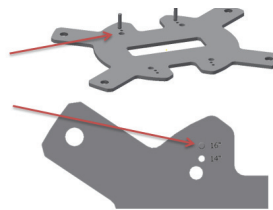

Figure 54

**5.0.12)** Thread in all four of the fully threaded 4" posts (see Figure 55).

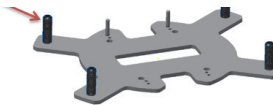

Figure 55

**NOTE:** Make sure alignment pins and threaded posts are not threaded past flush with the back surface of the cartridge alignment plate.

**5.0.13)** Insert insertion tool knurled handle end of the cartridge assembly into equipment. Advance the 14"/16" cartridge assembly into the housing until the cartridge is supporting its own weight in the insertion housing.

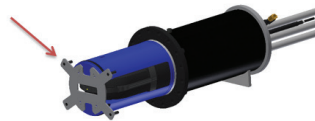

Figure 56

**5.0.14)** Once the cartridge has been inserted to this point, the cartridge alignment plate may be mounted to the bottom of the cartridge with the 3/8" alignment pins fully inserted into the gate housing and the plate flush with the bottom surface of the gate housing (see Figure 56).

**5.0.15)** Place the stop collar and alignment plate over the insertion tool. Do not tighten either the stop collar or the alignment plate.

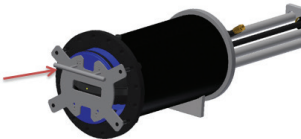

Figure 57

**5.0.16)** The lifting handle may now be used to lift and progress the cartridge further into the insertion housing by inserting the two prongs of the handle through the 5/8" holes of the plate and into the 5/8" holes in gate housing (see Figure 57).

**5.0.17)** Once progressed to within approximately 4 inches of the equipment flange, the cartridge must be lifted to align the threaded studs with the insertion housing flange holes (see

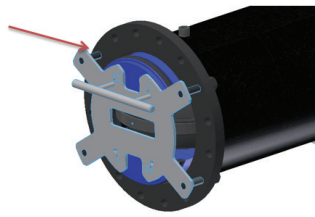

Figure 58

Figure 58).

**CAUTION:** CARTRIDGES ARE HEAVY. LIFTING SHOULD ALWAYS BE DONE WITH TWO PEOPLE TO AVOID INJURY. IT IS RECOMMENDED THAT LIFTING HANDLE BE USED ONLY BY HAND AND NOT WITH A LIFTING DEVICE.

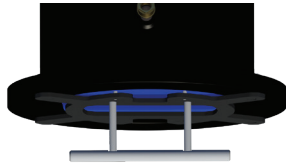

Figure 59

**5.0.18)** Once threaded studs are aligned, insert cartridge until cartridge alignment plate is flush with insertion housing flange face (see Figure 59).

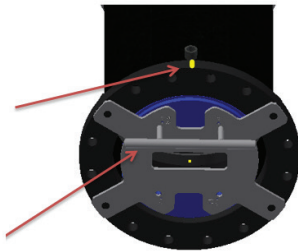

Figure 60

**5.0.19)** Thread and hand tighten the four 1"–8 nuts until they are completely tight, so the cartridge alignment plate is flush with the insertion housing flange.

**NOTE:** If there is not already a mark on the insertion housing, make a line between the top 2 flange holes on the insertion housing. This line must be in line with the pipe for a proper installation (see Figure 60).

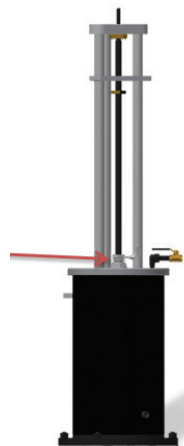

Figure 61

**5.0.20)** Before lifting vertical, the lifting handle must be removed.

**5.0.21)** Lift the insertion housing vertically onto the alignment plate. Ensure packing nut thumb screw is loose and that cartridge is sitting flush against the cartridge alignment plate (see Figure 61).

**5.0.22)** Set the stop collar the following distances from the top of the packing nut: (see Figure 62).

- 14" Cartridge = 29.75 in
- 16" Cartridge = 31.75 in

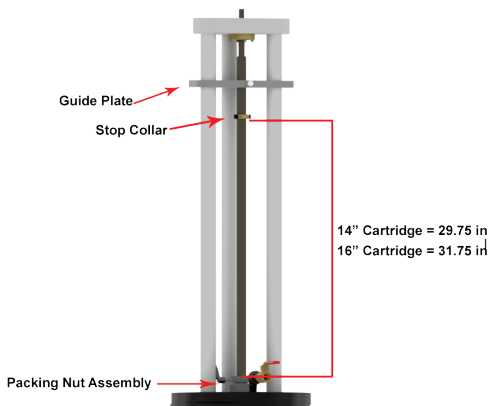

Figure 62

**5.0.23)** Tighten the stop collar.

**5.0.24)** Adjust and place the guide plate slightly (approximately 2 inches) above the stop collar.



Figure 63  
Split Guide Plate

**NOTE:** If you are using a split guide plate (see Figure 63) with the guide plate restraint:

- 1) First, tighten the restraint piece to the guide plate.
- 2) Then tighten the guide plate to the insertion tool.

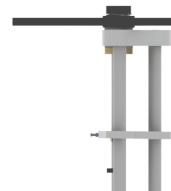

Figure 64  
One-Piece Guide Plate

**NOTE:** If you have a one-piece guide plate (see Figure 64), tighten the guide plate screw to the insertion tool.

**5.0.25)** Before lifting insertion housing onto the 16" Temporary gate valve, FIRMLY tighten packing nut thumb screw and unscrew the four 1"–8 nuts holding the alignment plate gauge (see Figure 65).

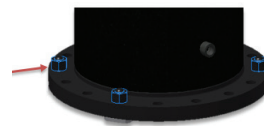

Figure 65

**5.0.26)** Lift the insertion housing off the alignment gauge plate and carefully place on the temporary gate valve (see Figure 66).

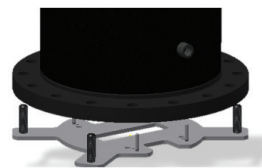

Figure 66

### Section 5.1 Valve Cartridge Insertion

**5.1.1)** With lift support, place the installation housing onto the temporary gate valve. The alignment port of the installation housing is to be positioned for alignment in line with the pipe and faced away from webbing of the temporary gate valve.

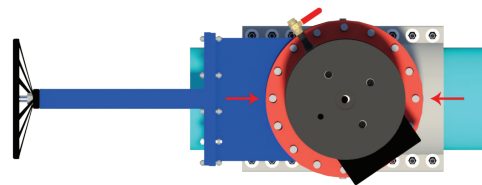

Figure 67 — Alignment nut placement for insertion housing alignment

**5.1.2)** Thread 2 alignment nuts onto the studs which connect the insertion housing to the temporary gate valve. Place these nuts at the locations shown in Figure 67. Install alignment nuts so that the tapered part of the nut enters the flange hole.

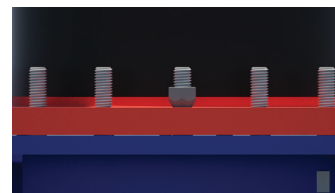

Figure 68

This may require adjustment of the gate valve or installation housing. Figure 68 shows the installed temporary gate valve alignment nut.

5.1.3) Tighten the alignment nuts.

5.1.4) Thread the remaining nuts over the temporary gate valve studs. Tighten all nuts evenly and gradually in a crossing pattern.

5.1.5) Thread the feed screw into the P3 until the feed screw bottoms out on the thrust washer of the insertion tool.



Figure 69

5.1.6) Open the valve at the top of the installation housing to purge air from inside of the housing before opening the temporary gate valve (see Figure 69).

5.1.7) Slowly open the temporary gate valve and close the valve on the top of the installation housing after water has discharged.

5.1.8) Continue to open the temporary gate valve until it is fully open. Tighten the packing on the temporary gate valve as needed to minimize any leakage past the packing.

**NOTE:** A tighter packing makes temporary gate valve operation more difficult and can be loosened as needed when operation is required.

5.1.9) Loosen the clamp lever in the packing nut by turning the thumb screw in the counterclockwise direction.

5.1.10) Turn the feed screw in the clockwise direction to insert the valve cartridge into the valve body, continue until further turning is difficult, which should be less than 3" to full travel when the top gate housing O-ring first engages the bore inside of the valve it seals upon. At this point, the O-ring has isolated the installation housing from the line pressure and further valve cartridge travel would cause pressure in the housing to drop below pressure in the pipe.

5.1.11) Continue to lower the valve assembly by turning the feed screw until it bottoms out on its stop. Increased resistance will be encountered as the cartridge O-ring begins to seat. Continue turning the feed screw until the cartridge reaches a positive stop, indicating full travel has been achieved. If it appears a small amount of travel is required, rather than immediately applying greater force to the feed screw when the valve assembly may have bottomed out, check to see if a pin installs (see steps 5.1.13–5.1.14), which would show full travel has been achieved.

5.1.12) Remove a plug on the side of the flange at top of the Insta-Valve Plus that is in line with the pipe and opposite the bonnet of the temporary gate valve.



Figure 70

5.1.13) Thread the pin that is exposed after removing the plug in the clockwise direction until it bottoms out. Approximately 8–10 full turns are required to seat the pin. Do not continue to thread pin in with additional force after it has bottomed out. Once

bottomed out, back off 1/2 turn (see Figure 70).

5.1.14) Check the depth of the pin with the pin gauge to confirm the pin has bottomed out inside of its slot in the completion plug. The gauge bottoms out on the valve body flange when the pin is fully installed.

**CRITICAL NOTE:** The valve assembly is not secured in the valve body until all pins, not blocked by the temporary gate valve, have been fully installed.

**NOTE:** If the initial test pin does not fully install, see directions in Appendix A for "Second Valve Insertion Attempt." Continue to maintain installation housing pressure slightly above line pressure.

5.1.15) After full installation of the first pin and is confirmed by the gauge, fully install, and check every pin starting with the pins 90° from the first pin and then the next two pins on the opposite side of the first pin.

**NOTE:** Sufficient clearance is provided to install the pin that is in line with the temporary gate valve with a ratchet and hex bit socket for the temporary gate valve model that requires additional valve insertion travel.

## Section 5.2 Complete Installation

**NOTE:** Do not start the next step until all completion pins have been properly set. Failure to properly set the completion pins could result in hard operation and impact valve performance.

5.2.1) Raise the feed screw 1 inch to expose the insertion tool lock nut.

5.2.2) Attach a 10' hose to the 3/4" ball valve on the insertion housing, then run the opposite end to a discharge location outside of the excavation.



Figure 71

5.2.3) Use a 3/4" open-ended wrench to loosen the lock nut until the outer shaft of the insertion tool can be raised to allow the auto equalizing check valve to close (see Figure 71).

5.2.4) Slowly open the ball valve. A light stream of water will begin to flow from the hose.

5.2.5) Continue to turn the insertion tool lock nut, raising the feed screw 1 inch at a time as needed, to fully disengage the insertion tool from the valve cartridge.

5.2.6) The light (4 gal/min) stream of water out of the 3/4" ball valve should begin to decrease and stop as the insertion tool is disengaged from the valve cartridge.

5.2.7) Lock the clamp lever.

5.2.8) Remove the feed screw.

5.2.9) Loosen the clamp lever.

5.2.10) Raise the insertion tool up to the start position, where

the knurled handle extends past the P3 of the tapping machine and secure the insertion tool in place by tightening the clamp lever.

**5.2.11)** Remove the nuts securing the installation housing to the temporary gate valve.

**5.2.12)** With lift support and a strap around the P3 lift the installation housing from the temporary gate valve.

**5.2.13)** Remove the nuts securing the temporary gate valve to the top of the Insta-Valve Plus 250. Leave a nut in place opposite the valve bonnet until the valve is sufficiently supported by lift support and then remove the last nut. Remove the temporary gate valve from the Insta-Valve Plus 250 after all nuts have been removed.

**5.2.14)** Wrap pipe thread sealant tape around the threads of the plugs that were previously removed from the valve body flange.

**5.2.15)** Reinstall the set pin plugs into the valve body flange and check to ensure all plugs are tight.

**5.2.16)** Remove the auto-e pins from the top of the cartridge.

**5.2.17)** Apply Teflon tape to the 3/8" NPT plugs and thread them back into the Auto Equalization check valves.

**5.2.18)** Place the O-ring for the valve body flange into its O-ring groove.

**5.2.18)** Apply a small amount of grease to the inside O-Ring in the valve bonnet.

**5.2.19)** Place the bonnet over the top of the valve stem and onto the O-ring on top of the Insta-Valve Plus 250. The valve stem is to fit through the hole at the center of the top flange.

**5.2.20)** Bolt the bonnet to the top of the Insta-Valve Plus 250. Apply torque evenly and gradually in a crossing pattern until the top flange is in contact with the raised face of the valve body flange and the bolts/nuts are tight.

**5.2.21)** Visually check around the flange to be sure the O-ring did not come out of its groove. If the O-ring is out of place, remove the nuts and bolts and restart at Step 5.2.14.

**5.2.22)** Place the operating nut onto the valve stem extending out of the top flange.

**5.2.23)** Place the lock washer over the valve stem threads and tighten the retaining nut onto the threads until the lock washer is fully compressed to firmly hold the operating nut in place.

**NOTE:** For left-handed valves, the operating nut will need to be secured with a wrench to avoid closing the valve while tightening the retaining nut.

**5.2.24)** Test valve operation. Insta-Valve Plus 250 valves operate at a standard 3 turns-per-inch.

**5.2.25)** Fully disassemble, clean, and store equipment.

**5.2.26)** Order replacement parts, if necessary, to replace lost, damaged, or worn components.



# INSTA-VALVE PLUS 250 **INSERTION VALVES**

Appendices



## Appendix A — Technician Tool List

### Miscellaneous Supplies

- Tape Measure
- Torpedo Level
- Channel Lock Pliers
- Waterproof or Paint Marker
- Teflon Tape
- WD-40
- Chlorine Sprayer
- Spray Bottle With Soap and Water
- Food-Grade Grease (such as Primo-Lube)
- Pressure Test Kit Including Nipple Assembly

### Wrenches and Ratchets

- 3/4" Combination Wrench
- 3/8" Combination Wrench
- 7/16" Combination Wrench
- 1-1/4" Extra Deep Socket for Flange Nuts
- 1-5/8" Combination Wrench
- 1-1/2" Combination Wrench
- 1/2" or 3/8" Socket wrench

### Allen-Wrenches

- 3/8" Allen-T-handle, Short Handle Version
- 3/8" Allen-On 1/2" Drive Socket
- 5/8" Allen-Key
- 9/16" Allen-On 1/2" Drive Socket
- 9/16" Allen-Key, Standard
- 3/16" Allen-T-Handle, Long (10-inch long)

### Other Equipment

- Safety Equipment
- Hard Hat
- Safety Glasses
- Safety Shoes
- Fall Protection
- Hearing Protection
- Work Gloves
- Small Slings

**NOTE:** Have two sets of open-end wrenches on hand to allow multiple people to assist in installation.

**Appendix B — Using a Standard Pressure Test Flange to Pressure Test****Figure B-1**

**B.1)** Fill valve body with water (see Figure B-1).

**B.2)** Place O-ring into valve body O-ring groove.

**B.3)** Place pressure test flange onto valve body flange.

**B.4)** Insert flange bolts into the mounting holes of the pressure test flange. Tighten a washer and nut onto each of the eight bolts (see Figure B-2).

**Figure B-2**

**B.5)** Connect a pressure test assembly to the pressure test flange (see Figure B-3).

**B.6)** Connect pressure test assembly to your pressure source for pressure testing. Hydra-Stop recommends using a hydro-static method of pressurizing the valve body.

**NOTE:** DO NOT use a compressible medium such as air.

**B.7)** Follow local rules for the recommended length of the pressure test.

**B.8)** After completing pressure test, use ball valve to blow off pressure before removing pressure test flange.

**B.9)** Follow the tightening pattern and re-torque carriage bolts to recommended torque before continuing.

**NOTE:** DO NOT exceed recommended pressure test specifications.

- Minimum Test Pressure: 1.5 times the system working pressure.
- Maximum Test Pressure: 375 psi.

**Figure B-3**

**Appendix C — 14"–16" Valve Body installation instructions**

**IMPORTANT:** Read installation instructions COMPLETELY before installing the Insta-Valve Plus 250 valve body. Failure to follow installation instructions will void product warranty. Follow local safety regulations and use personal protection equipment (PPE) as required by national, state, and local regulations.

**INSTALLATION INSTRUCTION STEPS**

**C.1)** Inspect the valve body to ensure no damage has occurred during shipment or storage (see Figure C-1).

**C.2)** Unbolt and remove the top flange of the valve body and store the O-ring, nuts, and bolts in a place they will be free from debris (see Figure C-2).

**C.3)** Measure the outside diameter of the pipe and valve body clamp to confirm the correct size Insta-Valve Plus 250 is on hand for the installation.

**C.4)** Thoroughly clean the surface of the pipe over the area the Insta-Valve Plus 250 is to be installed.

**C.5)** Check the surface of the pipe where the gasket of the valve body is to seal to be sure there are no gouges, flaws, or extreme irregularities that would compromise a drip tight seal.

**C.6)** Lubricate the pipe and valve body gasket with soapy water. Do not use grease or pipe lubricant.

**C.7)** Using lift support, position the valve body onto the pipe in the position it is to be installed in so that adjusting of the valve's position is not necessary (see Figure C-3). A level should be used to check the orientation of the valve body flange during positioning. If repositioning is necessary lift the valve body off the pipe and retry. Do not rotate the valve body once it is on the pipe as this can cause damage to the gasket.

**NOTE:** Placing two bolts into the valve body flange, 180° apart and placing a strap over each bolt and above the flange is the recommended method of lifting.

**C.8)** Place the bottom sleeve of the valve body into position, underneath the pipe.

**C.9)** Install the bolts, nuts, and washers into the lug bar slots on the top and bottom sections of the valve body. A double set of washers is to be installed between each nut and the lug bars.

**NOTE:** The stainless steel hardware is to be kept clean and free from nicks. Debris and thread damage can cause the nut to seize on the stud. The use of a pneumatic wrench or similar can also cause the nuts to seize and is not to be used.

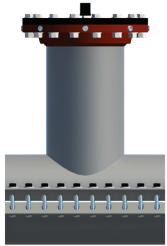

Figure C-1

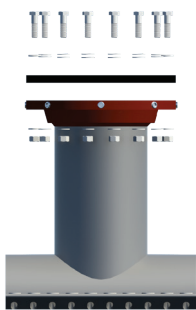

Figure C-2

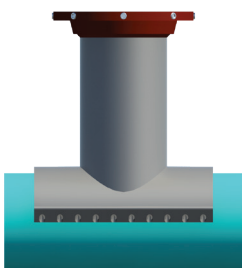

Figure C-3

**Installation instructions and best practices continued on next page.**

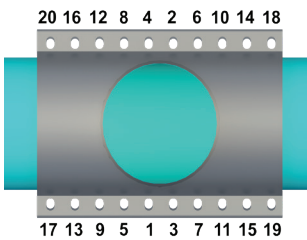
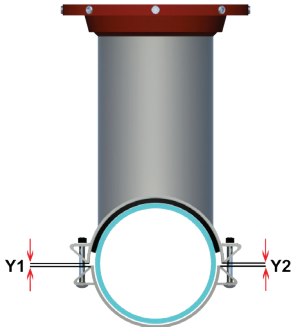

Figure C-4



Y1 AND Y2 ARE TO BE WITHIN  
1/8" ALONG THE LENGTH  
OF THE CLAMP.

Figure C-5

**C.10)** Once the nuts are hand tight, tighten the nuts following the torque pattern in Figure C-4. Tighten nuts evenly and alternate from one side of the valve to the other. The gaps between the top and bottom sleeves are to be equal on both sides (within 1/8"). Nuts are to be torqued to the values provided below. Be sure to follow this tightening procedure to properly load the gasket.

RECOMMENDED TORQUE:

Torque for CI / DI / Steel Pipe: 75 ft-lbs.

Torque for PVC Pipe: 55 ft-lbs.

Torque for AC Pipe: 75 ft-lbs.

**CRITICAL STEP:** Mounting the valve with equal gaps (1/8") on each side allows proper cutter travel during tapping and gate travel during valve operation (see Figure C-5).

**C.11)** Visually inspect inside of the valve to ensure the gasket on the inside of the top sleeve has remained in place. Check to ensure the depth of the pins threaded into the valve body flange are flush with the inside diameter of the flange.

**C.12)** After mounting valve body on pipe, perform a hydrostatic pressure test as detailed in the *Insta-Valve Plus 250 Installation and Operating Instructions* — Section 2 — Pressure Test Valve Body.

**C. 13)** Recheck torque after pressure test.

**INTALLATION BEST PRACTICES:**

- Retighten mounting bolts to specified torque after pressure test.
- Keep nuts and bolts clean and free of debris.
- Adequately lubricate pipe and valve body gasket with soap and water solution paying special attention to AC pipe. Ensure branch gasket is adequately lubricated. Do not use grease or pipe lubricants.
- Avoid rotating top half of valve body once placed on pipe.
- Tighten nuts equally in no more than 25 ft-lbs. increments.
- Wait at least 10 minutes before re-tightening bolts.
- Ensure gaps between top half and bottom half of valve body are the same front-to-back and side-to-side (within 1/8").
- Check final torque with a torque wrench to ensure adequate torque has been applied to valve body bolts.
- Do not use a pneumatic wrench to tighten bolts.
- Hydrostatically pressure test a minimum of 1.25 times the system pressure or a maximum of 1.5 times the rated working pressure of valve.
- Block / support the pipe before installing the tapping machine.

**Call Hydra-Stop for technical support at 800-538-7867 or 907-389-5111  
and visit us on the web at [www.hydra-stop.com](http://www.hydra-stop.com).**

**Appendix D — Valve Cartridge Insertion Without Auto Equalization**

**Section D1 — Valve Cartridge Setup**

**D1.1)** Measure and record the distance from the center of one of the eight ports on the outside diameter of the Insta-Valve Plus valve body flange to the top of the gasket lying flat on the top face of the temporary gate valve. This dimension will be used later to set the travel of the valve cartridge.

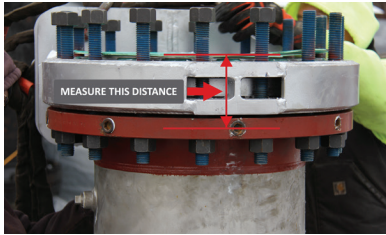

**Figure D-1**

If you are using a standard Hydra-Stop temporary gate valve, the measurement will be approximately 4 5/8 inches (see Figure D-1).

**D1.2)** Check to make sure the valve stem of the valve cartridge is tight and in the open position. Turn the operating nut in the open direction until tight, if necessary.

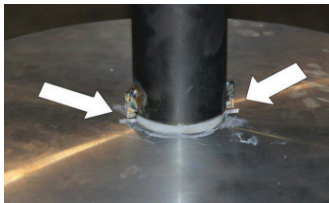

**Figure D-2**

**D1.3)** Unthread the retention nut and remove the operating nut from the valve stem.

**D1.4)** Place the head of the insertion tool over the valve stem protruding from the top of the valve cartridge, and align the square pegs on the insertion tool head with the slots in the completion plug on the top of the valve cartridge (see Figure D-2).

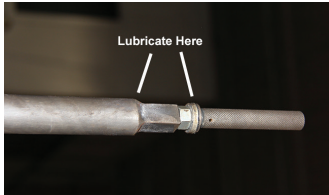

**Figure D-3**

**D1.5)** Add grease to the top of the insertion tool jam nut below the knurled handle (see Figure D-3).

**D1.6)** Thread the insertion tool onto the valve stem threads on the top of the valve assembly by turning the knurled handle on the top of the insertion tool in the clockwise direction until fully threaded. The head of the insertion tool bottoms out on the completion plug when it is fully threaded.

**D1.7)** Use an open-end wrench to tighten the 3/4" jam nut.

**CRITICAL STEP:** This step prevents rotation of the valve cartridge during insertion.

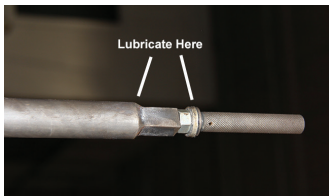

**Figure D-4**

**D1.8)** Add grease to the end of the insertion tool where the round shaft transitions to a chamfer (see Figure D-4).

**D1.9)** Add grease to the packing nut O-ring (see Figure D-5).

**D1.10)** Assemble the cartridge alignment plate by threading in two of the 3/8" threaded alignment pins. When installing a 14" cartridge, the holes closer



**Figure D-4**

to the center of the plate should be used. When installing a 16" cartridge, the holes further from center should be used (see Figure D-6).

**D1.11)** Thread in all four of the fully threaded 4" posts (see Figure D-7).

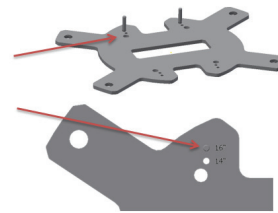

**Figure D-6**

**NOTE:** Make sure alignment pins and threaded posts are not threaded past flush with the back surface of the cartridge alignment plate.

**D1.12)** Insert insertion tool knurled handle end of the cartridge assembly into equipment. Advance the cartridge assembly into the housing until the cartridge is supporting its own weight in the insertion housing.



**Figure D-7**

**D1.13)** Once the cartridge has been inserted to this point, the cartridge alignment plate may be mounted to the bottom of the cartridge with the 3/8 alignment pins fully inserted into the gate housing and the plate flush with the bottom surface of the gate housing (see Figure D-8).

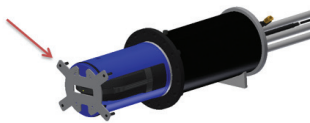

**Figure D-8**

**D1.14)** Place the stop collar and alignment plate over the insertion tool. Do not tighten either the stop collar or the alignment plate.

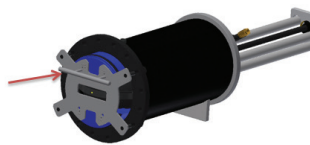

**Figure D-9**

**D1.15)** The lifting handle may now be used to lift and progress the cartridge further into the insertion housing by inserting the two prongs of the handle through the 5/8" holes of the plate and into the 5/8" holes in gate housing (see Figure D-9).

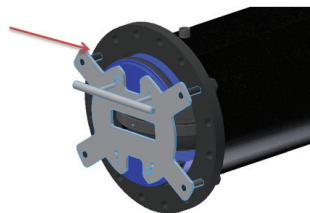

**Figure D-10**

**D1.16)** Once progressed to within approximately 4 inches of the equipment flange, the cartridge must be lifted to align the threaded studs with the insertion housing flange holes (see Figure D-10).

**CAUTION:** CARTRIDGES ARE HEAVY. LIFTING SHOULD ALWAYS BE DONE WITH TWO PEOPLE TO AVOID INJURY. IT IS RECOMMENDED THAT LIFTING HANDLE BE USED ONLY BY HAND

AND NOT WITH A LIFTING DEVICE.

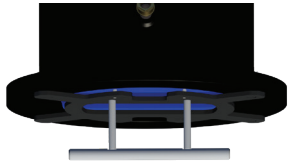

Figure D-11

**D1.17)** Once threaded studs are aligned, insert cartridge until cartridge alignment plate is flush with insertion housing flange face (see Figure D-11).

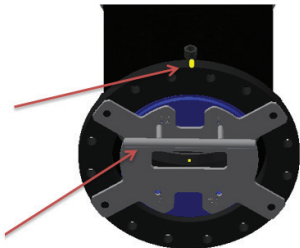

Figure D-12

**D1.18)** Thread and hand tighten the four 1"–8 nuts until they are completely tight, so the cartridge alignment plate is flush with the insertion housing flange.

**NOTE:** If there is not already a mark on the Insertion Housing, make a line between the top 2 flange holes on the insertion housing. This line must be in line with the pipe for a proper installation (see Figure D-12).

**D1.19)** Before lifting vertical, the lifting handle must be removed.

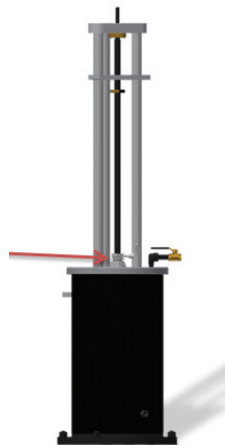

Figure D-13

**D1.20)** Lift the insertion housing vertically onto the alignment plate. Ensure packing nut thumb screw is loose and that cartridge is sitting flush against the cartridge alignment plate (see Figure D-13).

**D1.21)** Set the stop collar the following distances from the top of the packing nut: (see Figure D-14 for reference.)

- 14" Cartridge = 29.75 in
- 16" Cartridge = 31.75 in

**D1.22)** Tighten the stop collar.

**D1.23)** Adjust and place the guide plate slightly (approximately 2 inches) above the stop collar.

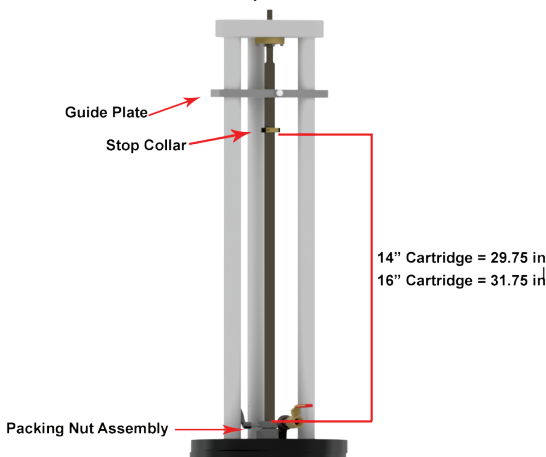

Figure D-14

**NOTE:** If you are using a split guide plate (see Figure D-15) with



Figure D-15  
Split Guide Plate

**the guide plate restraint:**

- 1) First, tighten the restraint piece to the guide plate.
- 2) Then tighten the guide plate to the insertion tool.

**NOTE:** If you have a one-piece guide plate (see Figure D-16), tighten the guide plate screw to the insertion tool.



Figure D-16  
One-Piece Guide Plate

**D1.24)** Before lifting Insertion housing onto the 16" Temporary gate valve, FIRMLY tighten packing nut thumb screw and unscrew the four 1"–8 nuts holding the alignment plate gauge (see Figure D-17).

**D1.25)** Lift the insertion housing off the alignment gauge plate and carefully place on the temporary gate valve (see Figure D-18).

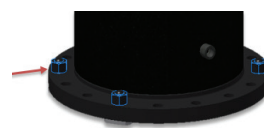

Figure D-17

**Section D2 — Valve Cartridge Insertion**

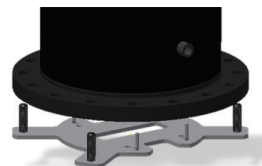

Figure D-18

**D2.1)** With lift support, place the installation housing onto the temporary gate valve. The alignment port of the installation housing is to be positioned for alignment in line with the pipe and faced away from webbing of the temporary gate valve.

**D2.2)** Thread 2 alignment nuts onto the studs which connect the insertion housing to the temporary gate valve. Place these nuts at the locations shown in Figure D-19. Install alignment nuts so that the tapered part of the nut enters the flange hole.

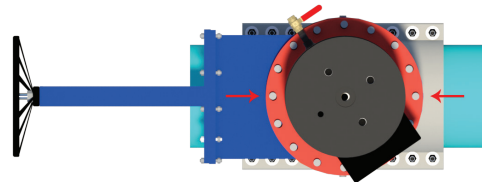

Figure D-19  
Alignment nut placement for insertion housing alignment

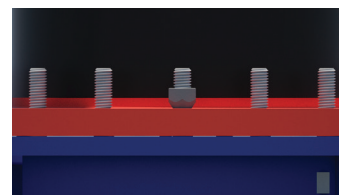

Figure D-20

This may require adjustment of the gate valve or installation housing. Figure D-20 shows the installed temporary gate valve alignment nut.

**D2.3)** Tighten the alignment nuts.

**D2.4)** Thread the remaining nuts over the temporary gate valve studs. Tighten all nuts evenly and gradually in a crossing pattern.



Figure D-21

**D2.5)** Thread the feed screw into the P3 until the feed screw bottoms out on the thrust washer of the insertion tool.

**D2.6)** Open the valve at the top of the installation housing to purge air from inside of the housing before opening the temporary gate valve (see Figure D-21).

**D2.7)** Slowly open the temporary gate valve and close the valve on the top of the installation housing after water has discharged.

**D2.8)** Continue to open the temporary gate valve until it is fully open. Tighten the packing on the temporary gate valve as needed to minimize any leakage past the packing.

**NOTE:** A tighter packing makes temporary gate valve operation more difficult and can be loosened as needed when operation is required.

**D2.9)** An equalization source (such as an equalization pump) is required to pressurize the installation housing.

**D2.10)** Connect or place a hose from the equalization pump to the water reservoir. Install the pressurization assembly into the top port of the installation housing.



Figure D-22

**D2.11)** Connect the red hose from the pump to the nipple on the pressurization ball valve (see Figure D-22 and D-23).

**D2.11)** Fill the reservoir with water. Open the lower insertion housing ball valve and allow water to fill the reservoir. A minimum of 25 gallons of water will be needed to ensure the pump does not run dry. Close the ball valve after collecting water.

**NOTE:** 25 gallons is sufficient provided temporary gate valve packing leakage is not excessive and the insertion process is not prolonged for any reason.

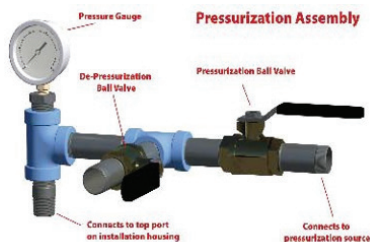

Figure D-23

**D2.12)** Using an air compressor or equalization pump, apply pressure above the system line pressure (+ 5–10 Psi) to the equalization line/hose at the pump's outlet through the top installation housing port. If using a compressor to equalize pressure, a check valve should be used to prevent water from flowing into the compressor.

**D2.13)** If the equalization pump is used for pressurizing the

housing, be sure the reservoir hose is filled before starting the pump.

**NOTE:** Take caution to ensure the end of the inlet hose remains submerged in water, and check water level frequently to avoid pressure loss in the installation housing.

**D2.14)** Plug in the pump. Open the pressurization ball valve. Ensure de-pressurization ball valve is closed (see Figure D-23).

**D2.15)** Loosen the clamp lever in the packing nut by turning the thumb screw in the counterclockwise direction.

**D2.16)** Turn the feed screw in the clockwise direction to insert the valve cartridge into the valve body, continue until further turning is difficult, which should be less than 3" to full travel when the top gate housing O-ring first engages the bore inside of the valve it seals upon. At this point, the O-ring has isolated the installation housing from the line pressure and further valve cartridge travel would cause pressure in the housing to drop below pressure in the pipe.

Turn pump on and allow pressure to build to desired range. Watch the pump pressure gauge and maintain desired pressure by cycling pump on-off switch.

**D2.17)** Continue to increase pressure in the housing above the system line pressure until full valve assembly travel can be achieved with only slight downward force to the insertion tool through the feed screw (do not exceed 375 psi using 250 psi rated installation equipment).

**D2.18)** Continue to lower the valve assembly by turning the feed screw until it bottoms out on its stop. Increased resistance will be encountered as the cartridge O-ring begins to seat. Continue turning the feed screw until the cartridge reaches a positive stop, indicating full travel has been achieved. If it appears a small amount of travel is required, rather than immediately applying greater force to the feed screw when the valve assembly may have bottomed out, check to see if a pin installs (see steps D2.20–D2.21), which would show full travel has been achieved.

**D2.19)** With the installation housing pressurized slightly above line pressure, remove a plug on the side of the flange at top of the Insta-Valve Plus that is in line with the pipe and opposite the bonnet of the temporary gate valve.



Figure D-24

**D2.20)** Thread the pin that is exposed after removing the plug in the clockwise direction until it bottoms out. Approximately 8–10 full turns are required to seat the pin. Do not continue to thread pin in with additional force after it has bottomed out. Once bottomed out, back off 1/2 turn (see Figure D-24).

**D2.21)** Check the depth of the pin with the pin gauge to confirm the pin has bottomed out inside of its slot in the completion plug. The gauge bottoms out on the valve body flange when the pin is fully installed.

**CRITICAL NOTE:** The valve assembly is not secured in the valve body until all pins, not blocked by the temporary gate valve, have been fully installed.

**NOTE:** If the initial test pin does not fully install, see directions in Appendix F for "Second Valve Insertion Attempt". Continue to maintain installation housing pressure slightly above line pressure.

**D2.22)** After full installation of the first pin and is confirmed by the gauge, fully install, and check every pin starting with the pins 90° from the first pin and then the next two pins on the opposite side of the first pin. Continue to keep the installation housing pressurized slightly above the line pressure throughout this process. If the equalization pump is being used to pressurize the housing, monitor the water level. If the pressure in the housing is higher than necessary and resulting in leakage past the packing of the temporary gate valve, the pressure can be slowly lowered to a pressure still above line pressure to conserve water.

**NOTE:** Sufficient clearance is provided to install the pin that is in line with the temporary gate valve with a ratchet and hex bit socket for the temporary gate valve model that requires additional valve insertion travel.

**D2.23)** Return to Section 5.2 – Complete Installation on page 14 in the main instructions.



**Appendix E — Valve Cartridge and Cutter Sizing Information****14" / 16" Cutter and Valve Cartridge Selection**

Nominal Size	Cutter Size	Cutter Color	ID Range	Valve Cartridge Part Number
14"	13.3"	<b>Blue</b>	13.2"–13.8"	25CARTLH14-250-AC
	13.3"	<b>Blue</b>	13.2"–13.8"	25CARTLH14-250-U13.3
	13.8"	<b>Black</b>	13.7" - 14.5"	25CARTLH14-250
16"	15.3"	<b>Blue</b>	15.2"–15.8"	25CARTLH16-250-AC
	15.3	<b>Blue</b>	15.2" - 15.8"	25CARTLH16-250-U15.3
	15.8"	<b>Black</b>	15.7"–16.5"	25CARTLH16-250
	15.8	<b>Black</b>	15.7" - 16.5"	25CARTLH16-250-XT

\*NOTE: Extra turns are required to close and open the extra travel cartridge (25CARTLH16-250-XT).

## Appendix F — Second Valve Insertion Attempt

ENSURE INSTALLATION HOUSING PRESSURE IS SLIGHTLY ABOVE LINE PRESSURE.

**NOTE:** The installation housing should be filled with water and any air purged from the installation housing prior to relasing any pins.

**WARNING! NEVER FULLY OPEN INSTALLATION HOUSING BALL VALVES WHEN RELIEVING PRESSURE IN THE INSTALLATION HOUSING. RELIEVING PRESSURE IN AN UNCONTROLLED MANNER CAN CAUSE SUDDEN PRESSURE DIFFERENTIAL, WHICH MAY LEAD TO EQUIPMENT DAMAGE AND BODILY INJURY.**

F1.1) If full travel of the valve assembly has been achieved and the pin does not fully thread into the completion plug, the alignment of the valve cartridge is incorrect.

F1.2) Unthread any pins that fully installed 9 turns, to the start position to ensure there are no pins that will prevent the retraction of the valve cartridge to its start position.

**CRITICAL NOTE:** Exceeding 9 turns will allow the pin to come out of the flange under pressure. All people are to stand clear of the ports while unthreading pins as a safety precaution. Also, all workers are to stay clear of the path of the rising insertion tool.

F1.3) Slightly open the ball valve on the top of the insertion housing to allow water to begin to exit the housing which decreases pressure above the valve cartridge. Monitor the pressure in the insertion housing using a pressure gauge (see Figure F-1). The water pressure in the main will begin to raise the cartridge.



Figure F-1

**REMEMBER: NEVER FULLY OPEN INSTALLATION HOUSING BALL VALVES WHEN RELIEVING PRESSURE IN THE INSTALLATION HOUSING!**

F1.4) Turn the feed screw in the counterclockwise direction half of a turn to create a small gap between the insertion tool washers and feed screw.

F1.5) Bleed off approximately 5 psi from the installation housing pressure.

F1.6) If the valve cartridge rises with the feed screw, continue to unthread the feed screw from the P3 until the cartridge stops rising or has risen to the start position.

**CRITICAL NOTE:** During the first 2 3/4 inches of upward travel of the valve cartridge, maintaining a very small gap between the insertion tool washers and feed screw is critical to avoid rapid upward movement of the cartridge due to installation housing pressure loss, which can result in equipment damage.

F1.7A) If the valve assembly does not rise after lowering installation housing pressure, watch the gauge in the pressure assembly, slightly open the upper ball valve and bleed off an additional 5 psi from the installation housing pressure.

F1.7B) If the valve assembly still does not rise, bleed off an additional 5 psi from the installation housing pressure. DO NOT exceed a total of 15 psi differential between the installation housing pressure and the line pressure. Contact Hydra-Stop Technical Support if you reach the 15 psi differential and the valve assembly has not risen.

F1.8) When the valve assembly reaches approximately 2 3/4 inches of upward travel, retraction of the valve cartridge using line pressure has been completed. At this point the O-ring at the top of the cartridge is no longer engaged, which allows equalization above and below the cartridge.

F1.9) Tighten the cap screw in the packing nut to hold the valve cartridge in place.

F1.10) Close the ball valves on the top of the installation housing as external pressure is no longer needed.

F1.11) Loosen the cap screw in the packing nut and apply upward force to the guide plate to raise the valve cartridge to its starting position.

F1.12) Tighten the cap screw in the packing nut to hold the valve cartridge in place.

F1.13) Close the temporary gate valve. Open the ball valves at the top of the installation housing and open lower installation housing ball valve to drain the water.

F1.14) Remove the installation housing from the valve body.

F1.15) Return to Section 5.0 Valve Insertion Setup on page 12 and re-align valve cartridge.

F1.16) Thread the ball valve, in the closed position, back into the alignment port on the side of the installation housing. Repeat the Valve Cartridge Insertion process starting at Step 5.1.7 on page 14.

## Appendix G — Valve Insertion Without Alignment Gauge Plate

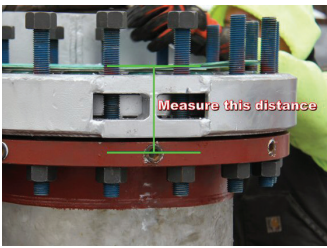

Figure G-1

be approximately 4 5/8 inches (see Figure G-1).

**G.2)** Check to make sure the valve stem of the valve cartridge is tight and in the open position. Turn the operating nut in the open direction until tight, if necessary.

**G.3)** Unthread the retention nut and remove the operating nut from the valve stem.

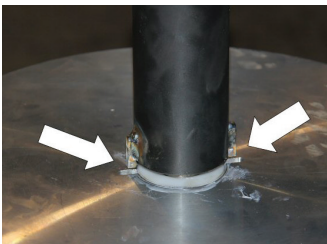

Figure G-2

**G.4)** Place the head of the insertion tool over the valve stem protruding from the top of the valve cartridge and align the square pegs on the insertion tool head with the slot in the completion plug on the top of the valve cartridge (see Figure G-2).

**G.5)** Add grease to the top of the insertion tool jam nut below the knurled handle (see Figure G-3).



Figure G-3

**G.6)** Thread the insertion tool onto the valve stem threads on the top of the valve assembly by turning the knurled handle in the clockwise direction until fully threaded. The head of the insertion tool bottoms out on the completion plug when it is fully threaded.

**G.7)** Use an open-end wrench to tighten the jam nut.

**CRITICAL STEP:** This step prevents rotation of the valve cartridge during insertion.



Figure G-4

**G.8)** Add grease to the packing nut O-ring (see Figure G-4).

**G.9)** With the valve assembly supported with a strap and lift support, and oriented with the insertion tool shaft parallel to the ground, guide the insertion tool through the packing nut at the top of the installation housing (installation housing to be lying on its side).



Figure G-5

**NOTE:** The packing nut threaded into the top of the installation housing will need to be sufficiently loose to take pressure of the packing chord and allow the insertion tool to pass through easily — unthread as needed (see Figure G-5).



Figure G-6

**G.10)** Insert the valve cartridge into the installation housing until the distance from the center of one of the eight milled slots on the outside diameter of the aluminum completion plug of the valve cartridge to the bottom flange face of the installation housing is equal to the measurement taken in Step G.1. The measurement will be approximately 4 5/8 inches (see Figure G-6).

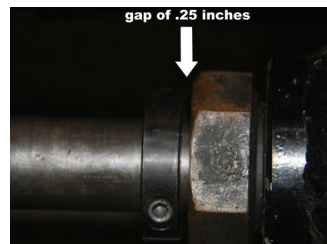

Figure G-7

**G.11)** Place a stop collar over the shaft of the insertion tool and tighten onto the shaft with a small gap of at least 1/4 inches above the top of the packing nut. The gap is necessary to ensure enough travel will be provided to completely install the valve cartridge. Make note of the small gap that was used (see Figure G-7).

**G.12)** Before the valve cartridge is fully installed into the installation housing, lubricate the valve assembly by applying generous amounts of food grade grease to the gate housing O-rings (top and bottom) and sides of the gate seal.

**G.13)** Place the guide plate over the knurled handle of the insertion tool and continue installing the valve cartridge into the housing.

**G.14)** Before the knurled handle of the insertion tool goes through the P3, move the guide plate down onto the shaft of the insertion tool.



Figure G-8

**G.15)** Insert gate housing extension rods into two holes on opposite sides of the gate in the bottom of the gate housing (see Figure G-8).

**G.16)** Continue inserting the valve assembly into the installation housing until it bottoms out. Lifting up on the

extension rods and pushing the valve cartridge into the housing may be needed to achieve the last three inches of travel before bottoming out.

**G.17)** Check and make note of the allowable travel provided by the distance of the stop collar above the top of the packing nut. This dimension should be approximately 30 5/8 inches plus the gap that was used to be sure sufficient travel will be allowed.

**G.18)** Rotate the valve cartridge inside the installation housing until the slot on the side of the gate housing is aligned with the alignment port on the side of the installation housing (See Figure G-9).



Figure G-9

Insert the alignment pin through the housing port and into the slot to verify and hold the position of the valve assembly. If the alignment pin does not bottom out on the port, proper alignment has not been achieved and the valve assembly must be rotated further (see Figure G-8 on previous page).

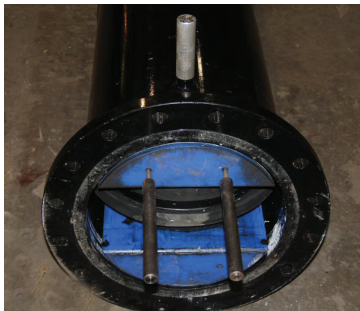

Figure G-10

**G.19)** Visually check to ensure proper valve cartridge orientation — the gate is to be perpendicular to the alignment port before continuing (see Figure G-10). Remove the gate housing extensions.

**G.20)** Position the guide plate about 6 inches above the stop collar.

**G.21)** Thread the Allen-cap screw into the guide plate until the clamp lever is closed tightly onto the insertion tool shaft. Tighten the jam nut on the cap screw by turning in the clockwise direction to hold the position of the cap screw.

**CRITICAL STEP:** This step prevents rotation of the valve assembly during insertion.

**G.22)** Tighten the packing nut at the top of the installation housing if it was previously loosened by turning in a clockwise direction. The packing nut must be sufficient tight to compress the packing which seals on the shaft of the insertion tool.

**G.23)** Tighten the clamp lever in the packing nut. The clamp lever must be sufficiently tight to hold the valve assembly inside of the installation housing.

**NOTE:** Before continuing to valve insertion, the technician(s) is to be familiar with the equalization pump operating manuals. The maintenance procedures are to be followed to keep equipment in good working order.

**G.24)** Adjust the pressure relief valve on the outlet line of the equalization pump to ensure pressure does not exceed 375 psi for 250 psi rated equipment and 225 psi for 150 psi rated equipment. This is accomplished by increasing the spring compression for higher pressure or decreasing for lower pressure by turning the spring stop, which can be accessed through the end of the valve with a 3/8" Allen-wrench.

Proceed to **Section 5.1 Valve Cartridge Insertion** on page 13.

**Appendix H — 14"–16" Core Sampling Parts Identification**

Item	Description	Quantity
1	Standard 16" Saw Mandrel (75" Long)	1
2	3/8 x 2" Adaptor Set Pin/Cotter	1
3	Cutter Attachment Hardware — 3/8-16 bolts	2
4	14/16 Mandrel Adaptor	1
5	4" Cutter	1
6	4" Pilot Bit	1
7	14" Centering Ring	1
8	16" Centering Ring	1
9	Centering Ring Adaptor Plate	1



**Materials Needed Post-Core Sampling Tapping**

10	13.3" Undersized Cutter (Blue)	1
11	15.3" Undersized Cutter (Blue — not shown)	1
12	13.8" Standard Cutter (Black — not shown)	1
13	15.8" Standard Cutter (Black)	1
14	Cutter Attachment Hardware 1/2-13 x 2" (3), 1/2-13x 2.5" (4), (7) Lock Nuts (not shown)	1
15	3/8" X 2" Centering Tool Set Pin / Cotter	1
16	4" Centering Tool	1
17	14/16" Centering Tool Adaptor	1

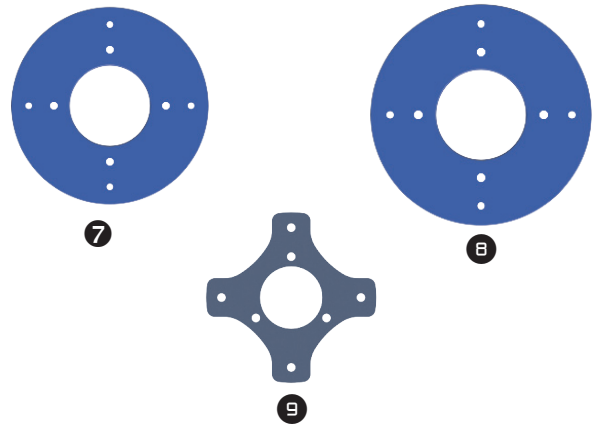

**14"–16" Standard Tool List**

18	T-Handle Allen Wrenches (5/32", 1/4", 5/16", 3/8")	5
19	3/4" Open-End Wrench	1

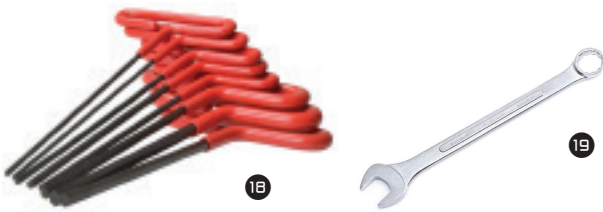
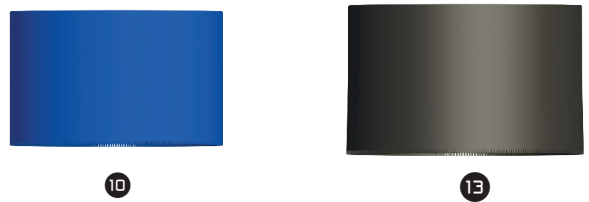

# INFORMATION AND NOTICES

## NOTICE:

This valve is equipped for using the Hydra-Stop Auto Equalization System.

Please see Section 5.0 for information on using Auto Equalization.

**NOTE:** These instructions depict the use of the most up-to-date Hydra-Stop insertion valves, installation equipment, and accessories. Please be certain you are following the instructions for your equipment.